



BDRAS

ALUMİNYUM GÖVDELİ SALYANGOZ FAN Öne Eğimli

BDRAS santrifüj fanlar düşük ses seviyesi, dayanıklı gövde yapısı, yüksek basınç özelliklerine sahiptir. Kompakt yapıları sayesinde yer tasarrufu sağlarlar.

Teknik Resim

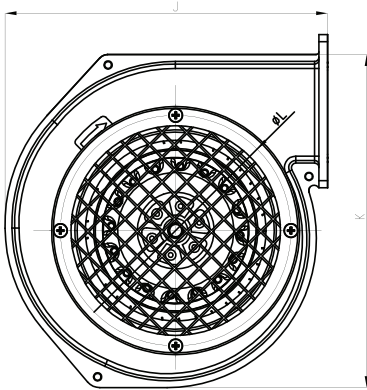
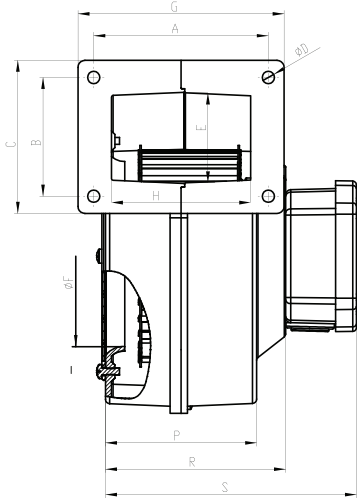

MALZEME

: Gövdesi; Alüminyum döküm
Radyal fan, öne eğimli kanat yapısı ile galvaniz sacdan üretilmiştir.

YALITIM SINIFI

: Class B

STANDART

: EN 60335-1, EN 60335-2-80

HIZ KONTROLÜ

: Opsiyonel kontrol cihazıyla sağlanabilir.
(BSC-1 / BSC-2)

KULLANIM ALANLARI

: BDRAS serisi fanlar özellikle endüstriyel ve ticari alanlarda; genel olarak lokal soğutma uygulamaları ve ısıtma sistemlerinde mükemmel çözümler sunarlar. Makinelerin soğutulmasında, katı yakıtlı kazanlarda, yat klimalarında, dc motor soğutmasında, plastik makinelerinde, çorap makinelerinde, elektrik panolarının soğutulmasında, laboratuvarlarda, konutlarda ve ticari mekânlarda vs. kullanılabilirler.

TİP	A	B	C	D	E	F	G	H	J	K	L	P	R	S
BDRAS 85-40	66	58	68	5,5	42	63	76	56	117,5	127,5	84	80	-	120
BDRAS 108-50	96	66	83	6,5	50	87	115	76	159	183	118	82	-	122
BDRAS 120-60	99	67,5	88	6,5	49	103,5	118,5	80	190	184	132	87	104	145
BDRAS 140-60	123	84	125	6,5	78	110	154	79	197	203	144,5	100	110	151
BDRAS 160-60	114	105	120	8	90	117,5	130	93,5	229	248	158	100	-	135

Ölçüler mm cinsindedir.

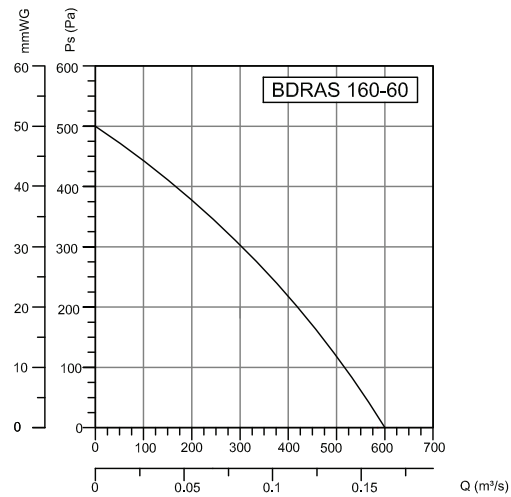
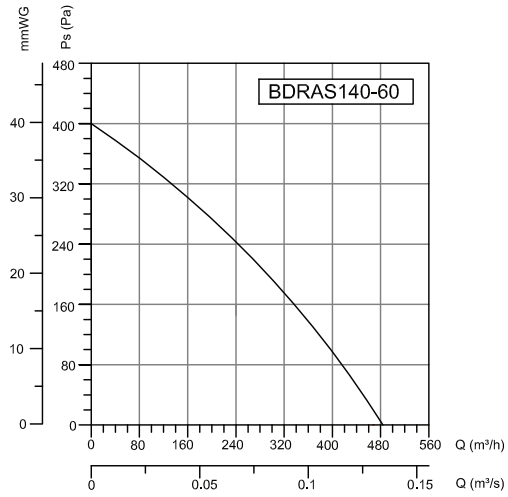
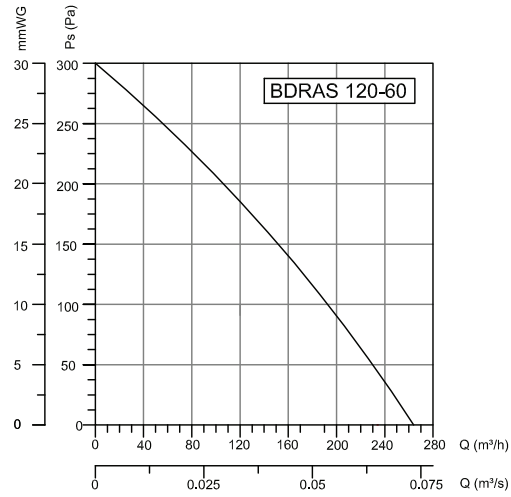
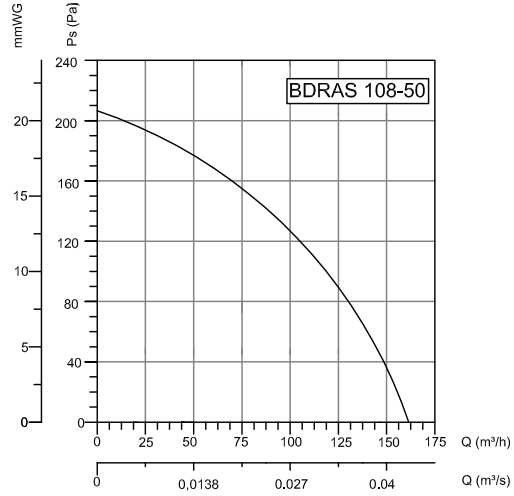
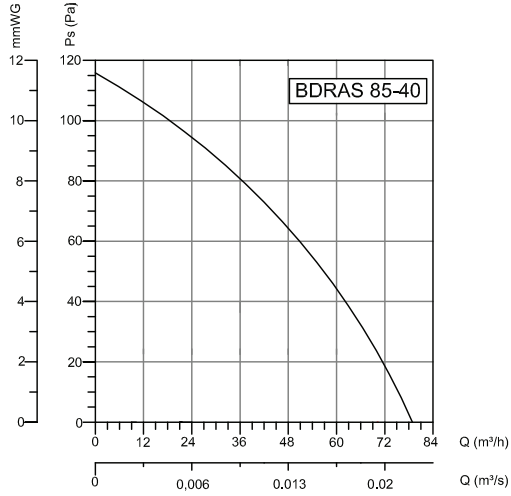

TİP	VOLTAJ	FREKANS	GÜÇ	AKIM	KONDANSATÖR	DEVİR	DEBİ	SES SEVİYESİ	AĞIRLIK
	V	Hz	W	(A)	(μ F)	d/d	m ³ /h	dB(A)	kg
BDRAS 85-40	230	50	33	0,16	1	2355	80	53	1,1
BDRAS 108-50	230	50	42	0,2	1,5	1660	155	53	1,4
BDRAS 120-60	230	50	84	0,37	2,5	2450	275	60	2,5
BDRAS 140-60	230	50	137	0,6	4	2265	485	70	3
BDRAS 160-60	230	50	193	0,85	5	2100	600	72	3,9

BDRAS FLANŞ ÖLÇÜLERİ

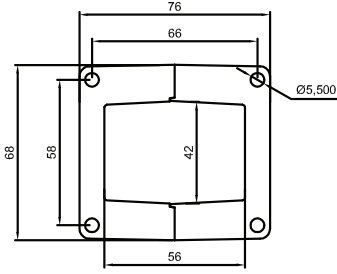

BDRAS 85-40

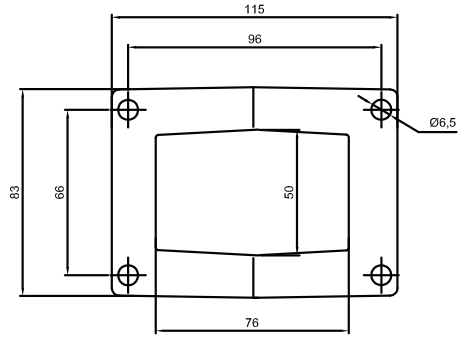

BDRAS 108-50

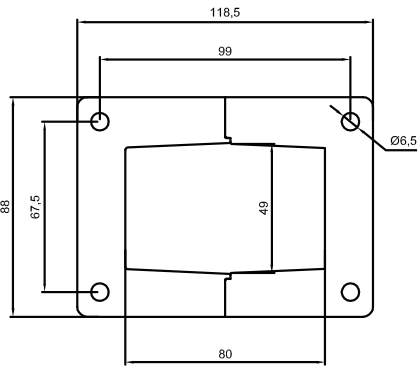

BDRAS 120-60

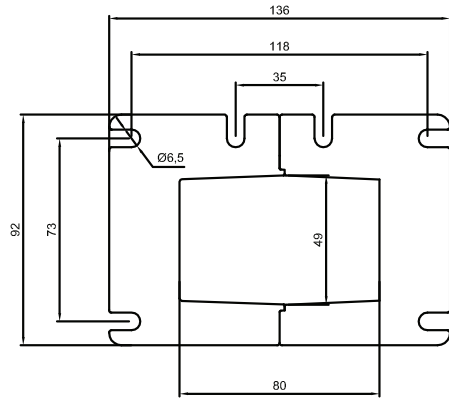

BDRAS 120-60

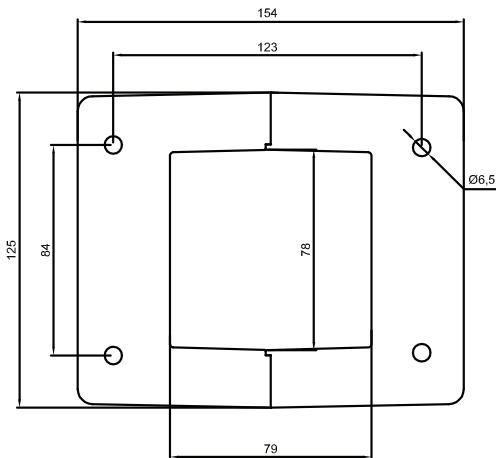

BDRAS 140-60

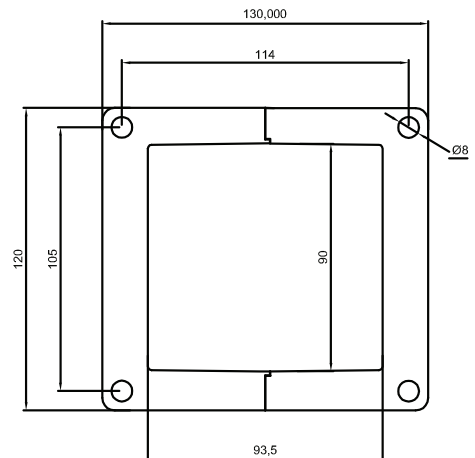

BDRAS 160-60



Aksesuarlar



BSC



KANAL FANLARI

ÇATI FANLARI

AKSİYEL FANLAR

RADYAL FANLAR

PLASTİK FANLAR

VANTİLATÖRLER

DUMAN EGZOST
SİSTEMLERİ

AKSESUARLAR